

Low power MEMS microphone with activity detection and adjustable gain

General description

Sparrow is a MEMS microphone designed for AI applications with analog signal output, level and frequency acoustic activity detection and adjustable signal gain. An interrupt line can notify or wake up a host controller whenever the acoustic activity exceeds a selectable threshold.

The signal output is implemented with a pair of complementary current sources, which makes the device compatible with differential signal receivers and also single ended receivers, having a voltage input or a current input. In addition to the built in adjustable resistors, an external resistor can be used to flexibly set the voltage gain.

This makes the device particularly suitable as sensor frontend for automated acoustic monitoring systems which need to be permanently listening, supporting the requirement to save power by reducing the average up-time of controlling units further down the signal chain, and offering the flexibility to dynamically adapt to changes in environmental acoustic conditions.

Diagram

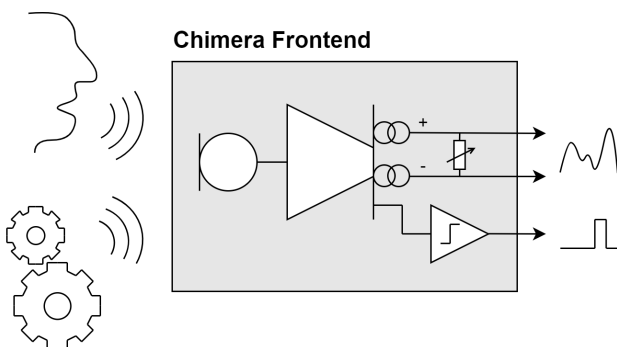

Features

- Acoustic activity detection with adjustable threshold level and frequency characteristic
- Analog output current pair providing a differential or a single ended signal
- Wide gain adjustment range with internal programmable resistors, and/or external resistors
- Sensitivity selection range exceeding -50...0 dBV at 94dB_{SPL}
- SPI interface and interrupt line
- Current consumption 19µA
- single 1.8V supply
- SNR 53dB_A, AOP 120dB_{SPL}
- Package 3.5x2.7mm with acoustic bottom port

Applications

- Always-listening monitoring and surveillance for maintenance, safety or entertainment
- First level detection stage in acoustic event recognition systems
- Automatic gain control (AGC) audio systems
- Keyword spotting applications

Package illustration

